

# Beogram 4000c

## Technical Sound Guide

Bang & Olufsen A/S

This manual is for information purposes only and is not legally binding.  
May 23, 2022

# Contents

<b>1 History</b>	<b>4</b>
1.1 The mechanical phonograph	4
1.2 Magnets and Coils	4
<b>2 The physics</b>	<b>5</b>
2.1 Amplitude vs. Velocity	5
2.2 Surface noise	5
2.3 Mono to Stereo	6
<b>3 The cartridge, stylus, and tonearm</b>	<b>8</b>
3.1 MMC: Micro Moving Cross	8
3.2 Signal Levels	9
3.3 Tip shape	11
3.4 Bonded vs. Nude	13
3.5 Tracking force	14
3.6 Effective Tip Mass	14
3.7 Compliance	14
3.8 Soundsmith SMMC20CL	15
3.9 Tangential Tracking	15
<b>4 Audio Specifications</b>	<b>17</b>
4.0.1 Magnitude Response	17
4.0.2 Rumble	17
4.0.3 Rotational speed	17
4.0.3.1 Accuracy	17
4.0.3.2 Stability	17
4.0.3.3 Measurement and Weighting	18
4.0.3.4 Expressing the result	19
<b>5 Reading the measurement datasheet</b>	<b>20</b>
5.1 Measurements from Vinyl	20
5.1.1 Magnitude Response	20
5.1.2 Channel Matching	21
5.1.3 Crosstalk	21
5.1.4 Rumble	21
5.1.5 Wow and Flutter	21
5.1.6 Frequency Drift	22
5.2 RIAA Preamplifier	22
5.2.1 Magnitude Response Deviation	22
5.2.2 Channel Matching	22
<b>6 Beogram 4000c Specifications</b>	<b>24</b>
<b>7 Further Reading</b>	<b>25</b>



## History

### 1.1 The mechanical phonograph

In 1856, Édouard-Léon Scott de Martinville invented a device based on the basic anatomy of the human ear. It consisted of a wooden funnel ending at a flexible membrane to emulate the ear canal and eardrum. Connected to the membrane was a pig bristle that moved with it, scratching a thin line into soot on a piece of paper wrapped around a rotating cylinder. He called this new invention a “phonautograph” or “self-writer of sound”.

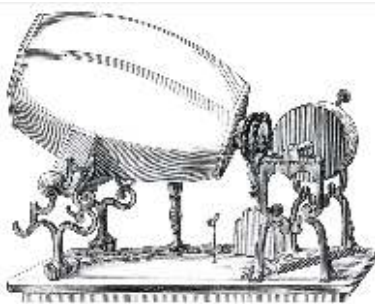

Figure 1.1: The phonautograph.

This device was conceived to record sounds in the air without any intention of playing them back, so it can be considered to be the precursor to the modern oscilloscope.<sup>1</sup> However, in the late 1870's, Charles Cros realised that if the lines drawn by the phonoautograph were photo-engraved onto the surface of a metal cylinder, then it could be used to vibrate a needle placed in the resulting groove. Unfortunately, rather than actually build such a device, he only wrote about the idea in a document that was filed at the Académie des Sciences and sealed. Within 6 months of this, in 1877, Thomas Edison asked his assistant, John Kruesi, to build a device that could not only record sound (as an indentation in tin foil on a cylinder) but reproduce it, if only a few times before

the groove became smoothed.<sup>2</sup>

It was ten years later, in 1887, that the German-American inventor Emil Berliner was awarded a patent for a sound recording and reproducing system that was based on a groove in a rotating disc (rather than Edison's cylinder); the original version of the system that we know of today as the “Long Playing” or “LP” Record.



Figure 1.2: An Edison “Blue Amberol” record with a Danish 78 RPM “His Master’s Voice” disc recording X8071 of Den Blaa Anemone.

Early phonographs or “gramophones” were purely mechanical devices. The disc (or cylinder) was rotated by a spring-driven clockwork mechanism and the needle or stylus rested in the passing groove. The vibrations of the needle were transmitted to a flexible membrane that was situated at the narrow end of a horn that amplified the resulting sound to audible levels.

### 1.2 Magnets and Coils

In 1820, more than 30 years before de Martinville's invention, the Danish physicist and chemist, Hans Christian Ørsted announced the first link made between electricity and magnetism: he had discovered that a compass needle would change direction when placed near a wire that was carrying an electrical current. Nowadays, it is well-known that this link is

bi-directional. When current is sent through a wire, a magnetic field is generated around it. The greater the current, the stronger the magnetic field, and the more it extends outwards around the wire. However, it is also true that moving a wire through a magnetic field will generate a current that is proportional to its velocity. In other words, the faster the wire moves through the magnetic field (or the magnetic field goes past the wire), the greater the current.

<sup>1</sup>It should be said that some “recordings” made on a phonautograph were finally played in 2008. See [www.firstsounds.org](http://www.firstsounds.org) for more information.

<sup>2</sup>see “Reproduction of Sound in High-fidelity and Stereo Phonographs” (1962) by Edgar Villchur

## The physics

### 2.1 Amplitude vs. Velocity

It is this second interaction that is at the heart of almost every modern turntable. As the stylus (or “needle”<sup>1</sup>) is pulled through the groove in the vinyl surface, it moves from side-to-side at a varying speed called the *modulation velocity* or just the *velocity*. An example of this wavy groove can be seen in the photo in Figure 2.1. Inside the housing of most cartridges are small magnets and coils of wire, either of which is being moved by the stylus as it vibrates. That movement generates an electrical current that is analogous to the shape of the groove: the higher the velocity of the stylus, the higher the electrical signal from the cartridge.

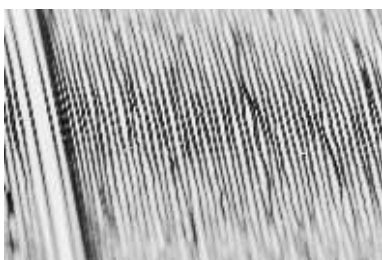

Figure 2.1: The groove in a late-1980’s pop tune on a 33 1/3 RPM stereo LP. The white dots in the groove are dirt that should be removed before playing the disc.

However, this introduces a problem because if the amplitude remains the same at all frequencies the modulation velocity of the stylus decreases with frequency; in other words, the lower the note, the lower the output level, and therefore the less bass. This is illustrated in the graph in Figure 2.2 in which three sine waves are shown with different frequencies. The blue line shows the lowest frequency and the orange line is the highest. Notice that all three have the same amplitude (the same maximum “height”). However, if you look at the slopes of the three

curves when they pass Time = 0 ms, you’ll see that the higher the frequency, the higher the slope of the line, and therefore the higher the velocity of the stylus.

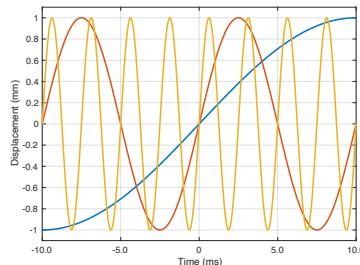

Figure 2.2: Three sine waves of different frequencies (from low to high: blue, red and orange curves), but with the same amplitude.

In order to achieve a naturally flat frequency response from the cartridge, where all frequencies have the same electrical output level, it is necessary to ensure that they have the same modulation velocity, as shown in Figure 2.3. In that plot, it can be seen that the slopes of the three waves are the same at Time = 0 ms. However, it is also evident that, when this is true, they have very different amplitudes: in fact, the amplitude would have to double for every halving of frequency (a drop of 1 octave). This is not feasible, since it would mean that the stylus would have to move left and right by (relatively) huge distances in order to deliver the desired output. For example, if the stylus were moving sideways by  $\pm 0.05$  mm at 1,000 Hz to deliver a signal, then it would have to move  $\pm 0.5$  mm at 100 Hz, and  $\pm 5$  mm at 10 Hz to deliver the same output level. This is not possible (or at least it’s very impractical).

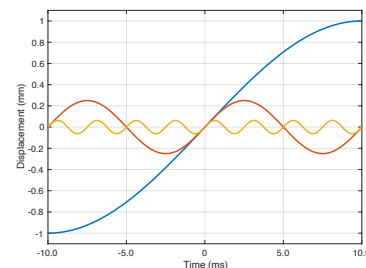

Figure 2.3: Three sine waves of different frequencies (from low to high: blue, red and orange curves), but with the same modulation velocity.

The solution for this limitation was to use low-frequency audio compensation filters, both at the recording and the playback stages. When a recording is mastered to be cut on a disc, the low frequency level is decreased; the lower the frequency, the lower the level. This results in a signal recorded on disc with a constant *amplitude* for signals below approximately 1 kHz.

Of course, if this signal were played back directly, there would be an increasing loss of level at lower and lower frequencies. So, to counteract this, a filter is applied to the output signal of the turntable that boosts the low frequencies signals to their original levels.

### 2.2 Surface noise

A second problem that exists with vinyl records is that of dust and dirt. If you look again at the photo in Figure 2.1, you can see white specks lodged in the groove. These look very small to us, however, to the stylus, they are very large bumps that cause the tip to move abruptly, and therefore quickly. Since the output signal is proportional to the modulation velocity, then this makes the resulting cracks and pops quite loud in relation to the audio signal.

In order to overcome this problem, a second filter is used, this time for higher frequencies. Upon playback, the

<sup>1</sup>Some authors reserve the term “stylus” for the device that is used to cut the groove during mastering, and the term “needle” for the device used to play a phonographic record. However, the two terms are used interchangeably in this document.

level of the treble is reduced; the higher the frequency the lower the output. This reduces the problem of noise caused by surface dirt on the disc, however it would also reduce the high frequency content of the audio signal itself. This is counteracted by increasing the level of the high-frequency portion of the audio signal when it is mastered for the disc.

This general idea of lowering the level of low-frequencies and/or boosting highs when recording and doing the opposite upon playback is a very old idea in the audio industry and has been used on many formats ranging from film “talkies” to early compact discs. Unfortunately, however, different recording companies and studios used different filters on phonographs for many years.<sup>2</sup> Finally, in the mid-1950s, the Recording Industry Association of America (the RIAA) suggested a standard filter description with the intention that it would be used world-wide for all PVC “vinyl” records.

Figures 2.4 and 2.5 show the responses of the RIAA filters used in both the mastering and the playback of long playing vinyl records. Although there are other standards with slightly different responses, the RIAA filter is by far the most commonly-used.

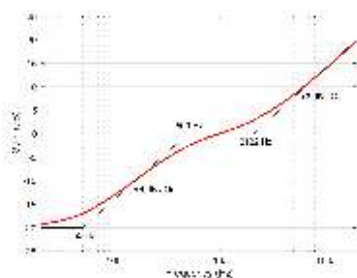

Figure 2.4: The “pre-emphasis” filter to be used in the mastering to disc, as described by the RIAA standard. The black line shows the simplified description, and the red curve shows the real-world implementation.

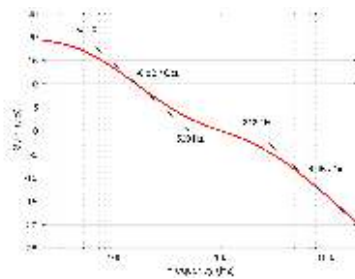

Figure 2.5: The “de-emphasis” filter to be used for playback as described by the RIAA standard. This standard filter response is integral in what is now commonly called a “RIAA preamp”.

It may be of interest to note that typical descriptions of the RIAA equalisation filter define the transition points as time constants instead of frequencies. So, instead of 50 Hz, 500 Hz, and 2,122 Hz (as shown in the response plots), the points are listed as 3,180 μs, 318 μs, and 75 μs instead. If you wish to convert a time constant (T<sub>c</sub>) to the equivalent frequency (F), you can use the equation below.

$$F = \frac{1}{2\pi T_c}$$

### 2.3 Mono to Stereo

In Edison’s first cylinder recordings, the needle vibrated up and down instead of left and right to record the audio signal. This meant that the groove cut into the surface of the tin foil was varying in depth, and therefore in width, as shown in Figure 2.6.

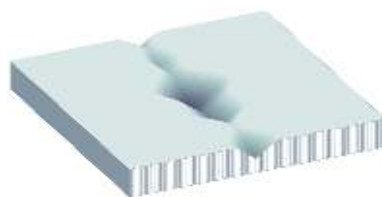

Figure 2.6: Example of an audio signal encoded using a vertical cutting system.

There are some disadvantages to this system, such as the risk of the needle

slipping out of the groove when it is too shallow, or suffering from excessive wear if the groove is too deep. In addition, any vertical variation in the recording surface (such as a cylinder that is not quite round, or mechanical vibrations in the player caused by footsteps in the room) becomes translated into unwanted noises upon playback.<sup>3</sup>



Figure 2.7: An Edison cylinder player, on display in the Struer Museum.



Figure 2.8: A closeup of the Edison player. Notice that the needle is mounted to move vertically, modulating a membrane located at the end of the tonearm (the bent pipe).

Berliner’s Gramophone used a different system, where the needle vibrated sideways instead. This lateral cut system produced a groove on the disc with a constant depth, thus avoiding some of the problems incurred by the vertical cut recording system.

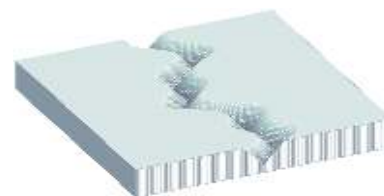

Figure 2.9: Example of an audio signal encoded using a lateral cutting system.

<sup>2</sup>see the [Manual of Analogue Sound Restoration Techniques \(2008\)](#), by Peter Copeland

<sup>3</sup>Some 78 RPM discs use a vertical cutting system as well, including those made by Edison Disc Records and Pathé.

However, both of these systems were only capable of recording a single channel of audio information. In order to capture 2-channel stereo audio (invented by Alan Blumlein in 1931) the system had to be adapted somehow. The initial challenge was to find a way of making a disc player that could reproduce two channels of stereo audio, while still maintaining compatibility with lateral-cut discs.

The solution was to rotate the modulation direction by  $45^\circ$ , so the two walls of the groove are used to record the two separate audio channels. This means that the stylus moves in two theoretically independent axes as shown in Figure 2.10. When the same signal is applied to both channels (better known as a “dual-mono” or “in-phase” signal), then the stylus moves upwards for the left while moving downwards for the right channel (or down-left & up-right), for example. This means that signals that are identical in both channels move the stylus laterally, exactly as in earlier monophonic discs.<sup>4</sup>

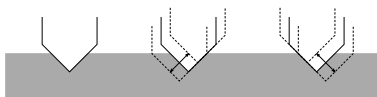

Figure 2.10: An over-simplified depiction of how the two audio channels are encoded in the groove. From left to right: No modulation (silence); Left channel signal modulates the groove's left wall; Right channel signal modulates the right wall.

As a result, if you look at the groove in a modern two-channel stereo LP, it appears that it simply wiggles left-to-right (as can be seen in Figure 2.1). However, if you inspect the same groove with extreme magnification, you can see that the modulations in the two sidewalls of the groove are slightly different, since the audio signals on the left and right channels are not identical.

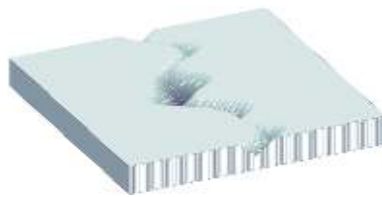

Figure 2.11: Example of two different signals encoded on the two channels of a stereo groove.

<sup>4</sup>For a more correct explanation of this movement, see [rfcafe.com/references/radio-electronics/stereo-disc-july-1958-radio-electronics.htm](http://rfcafe.com/references/radio-electronics/stereo-disc-july-1958-radio-electronics.htm)



## The cartridge, stylus, and tonearm

### 3.1 MMC: Micro Moving Cross

As mentioned above, when a wire is moved through a magnetic field, a current is generated in it that is proportional to the velocity of the movement. In order to increase the output, the wire can be wrapped into a coil, effectively lengthening the piece of wire moving through the field. Most phono cartridges make use of this behaviour by using the movement of the stylus to either:

- move tiny magnets that are placed near coils of wire (a *Moving Magnet* or *MM* design) or
- move tiny coils of wire that are placed near very strong magnets (a *Moving Coil* or *MC* design)

In either system, there is a *relative* physical movement that is used to generate the electrical signal from the cartridge. There are advantages and disadvantages associated with both of these systems, however, they will not be discussed here.

There is a third, less common design called a *Moving Iron* (or *variable-reluctance*<sup>1</sup>) system, which can be thought of as a variant of the Moving Magnet principle. In this design, the magnet and the coils remain stationary, and the stylus moves a small piece of iron instead. That iron is placed between the north and south poles of the magnet so that, when it moves, it modulates (or varies) the magnetic field. As the magnetic field modulates, it moves relative to the coils, and an electrical signal is generated. One of the first examples of this kind of pickup was the Western Electric 4A reproducer made in 1925.

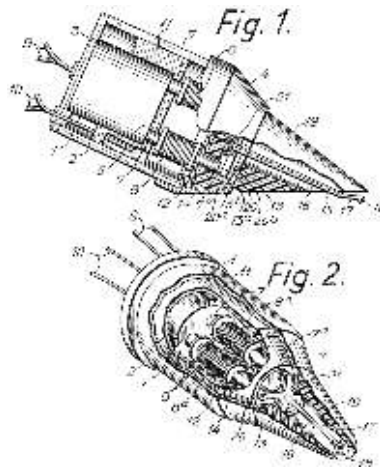

Figure 3.1: Figures from Rørbaek Madsen's 1963 patent for a Stereophonic Transducer Cartridge.

In 1963, Erik Rørbaek Madsen of Bang & Olufsen filed a patent<sup>2</sup> for a cartridge based on the Moving Iron principle. In it, a cross made of Mu-metal is mounted on the stylus. Each arm of the cross is aligned with the end of a small rod called a "pole piece" (because it was attached to the pole of a magnet on the opposite end). The cross is mounted diagonally, so the individual movements of the left and right channels on the groove cause the arms of the cross to move accordingly. For a left-channel signal, the bottom left and top right cross arms move in opposite directions - one forwards and one backwards. For a right-channel signal, the bottom right and top left arms move instead. The two coils that generate the current for each audio channel are wired in a push-pull relationship.



Figure 3.2: Erik Rørbaek Madsen explaining the MMC concept.

There are a number of advantages to this system over the MM and MC designs. Many of these are described in the original 1963 patent, as follows:

- "The channel separation is very good and induction of cross talk from one channel to the other is minimized because cross talk components are in phase in opposing coils."
- "The moving mass which only comprises the armature and the stylus arm can be made very low which results in good frequency response."
- "Hum pick-up is very low due to the balanced coil construction"
- "... the shielding effect of the magnetic housing ... provides a completely closed magnetic circuit which in addition to shielding the coil from external fields prevents attraction to steel turntables."

<sup>1</sup>reluctance is the magnetic equivalent of electrical resistance

<sup>2</sup>United States Patent 3,299,219

<sup>3</sup>Sound Recording Handbook", ed. Glen Ballou



- Finally, (although this is not mentioned in the patent) the push-pull wiring of the coils “reduces harmonic distortion induced by the non-linearity of the magnetic field.”<sup>3</sup>

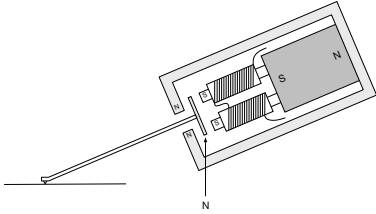

Figure 3.3: The magnetic circuit representation of the MMC cartridge, showing the diagonal pair of pole pieces for one of the two audio channels.



Figure 3.4: A disassembled MMC 1 cartridge. This magnetic circuit is slightly different than that shown in the diagram above. In this case, the magnet is the small square with the hole, shown on the right side of the photo. This is mounted at the front of the pickup instead of the rear. Note that the paper is ruled in 5 mm squares.

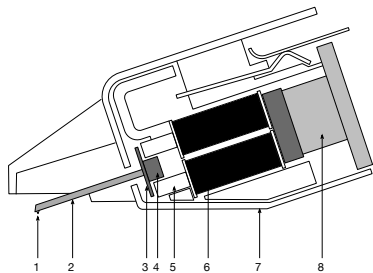

Figure 3.5: The Micro Moving Cross MMC 4000 cartridge design. 1. Nude Pramanik diamond, 2. Low mass beryllium cantilever, 3. Moving micro cross, 4. Block suspension, 5. Pole pieces (4), 6. Induction coils, 7. Mu-metal screen, 8. Hycomax magnet



Figure 3.6: Large-scale models of the MMC cartridges used for past demonstrations.

## 3.2 Signal Levels

Every audio device relies on a rather simple balancing act. The “signal”, whether it’s speech, music, or sound effects, should be loud enough to mask the noise that is inherent in the recording or transmission itself. The measurement of this “distance” in level is known as the *Signal-to-Noise Ratio* or *SNR*. However, the signal should not be so loud as to overload the system and cause distortion effects such as “clipping”, which results in what is commonly called *Total Harmonic Distortion* or *THD*.<sup>4</sup> One basic method to evaluate the quality of an audio signal or device is to group these two measurements into one value: the *Total Harmonic Distortion plus Noise* or *THD+N* value. The somewhat challenging issue with this value is that a portion of it (the noise floor) is typically independent of the signal level, since a device or signal will have some noise regardless of whether a signal is present or not. However, the distortion is typically directly related to the level of the signal.

In modern digital LPCM audio signals (assuming that they are correctly-implemented and ignoring any additional signal processing), the noise floor is the result of the dither that is used to randomise the inherent quantisation error in the encoding system. This noise is independent of the signal level, and entirely dependent on the resolution of the

system (measured in the number of bits used to encode each sample). The maximum possible level that can be encoded without incurring additional distortion that is inherent in the encoding system itself is when the maximum (or minimum) value in the audio signal reaches the highest possible signal value of the system. Any increase in the signal’s level beyond this will be clipped, and harmonic distortion artefacts will result.

Figure 3.7 shows two examples of the relationship between the levels of the signal and the THD+N in a digital audio system. The red line shows a 24-bit encoding, the blue line is for 16-bit. The “flat line” on the left of the plot is the result of the noise floor of the system. In this region, the signal level is so low, it’s below the noise floor of the system itself, so the only measurable output is the noise, and not the signal. As we move towards the right, the input signal gets louder and raises above the noise floor, so the output level naturally increases as well. However, in a digital audio system, we reach a maximum possible input level of 0 dB FS. If we try to increase the signal’s level above this, the signal itself will not get louder, however, it will become more and more distorted. As a result, the distortion artefacts quickly become almost as loud as the signal itself, and so the plots drop dramatically.

This is why good recording engineers typically attempt to align the levels of the microphones to ensure that the maximum peak of the entire recording will just barely reach the maximum possible level of the digital recording system. This ensures that they are keeping above the noise floor as much as possible without distorting the signals.

<sup>4</sup>The assumption here is that the distortion produces harmonics of the signal, which is a simplified version of the truth, but one that is easy to measure.

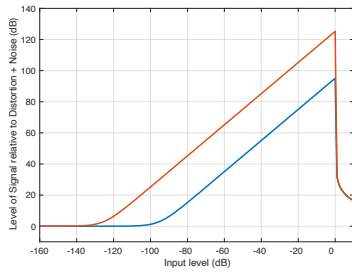

Figure 3.7: Two examples of the relationship between the levels of the signal and the THD+N in a digital audio system. These are idealised calculations, assuming TPDF dither in a “perfect” LPCM system. The red line shows a 24-bit encoding, the blue line is for 16-bit.

Audio signals recorded on analogue-only devices generally have the same behaviour; there is a noise floor that should be avoided and a maximum level above which distortion will start to increase. However, many analogue systems have a slightly different characteristic, as can be seen in the idealised model shown in Figure 3.8. Notice that, just like in the digital audio system, the noise floor is constant, and as the level of the input signal is increased, it rises above this. However, in an analogue system, the transition to a distorted signal is more gradual, seen as the more gentle slopes of the curves on the right side of the graph.

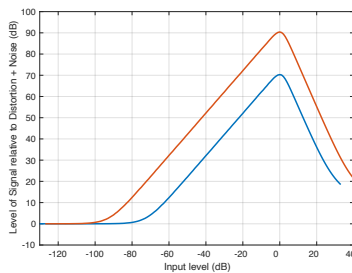

Figure 3.8: Two examples of the relationship between the levels of the signal and the THD+N in a simplified analogue audio system, showing two different maximum SNRs.

As a result, in a typical analogue audio

system, there is an “optimal” level that is seen to be the best compromise between the signal being loud enough above the noise floor, but not distorting too much. The question of how much distortion is “too much” can then be debated – or even used as an artistic effect (as in the case of so-called “tape compression”).

If we limit our discussion to the stylus tracking a groove on a vinyl disc, converting that movement to an electrical signal that is amplified and filtered in a RIAA-spec preamplifier, then a phonograph recording is an analogue format. This means, generally speaking, that there is an optimal level for the audio signal, which, in the case of vinyl, means a modulation velocity of the stylus, converted to an electrical voltage.

Although there are some minor differences of opinion, a commonly-accepted optimum level for the groove on a stereo recording is 35.4 mm/sec for a single audio channel at 1,000 Hz. In a case where both audio channels have the same 1 kHz signal recorded in phase (as a dual-monophonic signal), then this means that the lateral velocity of the stylus will be 50 mm/sec.<sup>5</sup>

Of course, the higher the modulation velocity of the stylus, the higher the output of the turntable. However, this would also mean that the groove on the vinyl disc would require more space, since it is being modulated more. This means that there is a relationship between the total playing time of a vinyl disc and the modulation velocity. In order to have 20 minutes of music on a 12” LP spinning at 33 1/3 RPM, the standard method was to cut 225 “lines per inch” or “LPI” (about 89 lines per centimetre) on the disc. If a mastering engineer wishes to have a signal with a higher output, then the price is a lower playing time (because the grooves much be spaced further apart to accommodate the higher modulation velocity at a wide

frequency bandwidth) however, in well-mastered recordings, this spacing is varied according to the dynamic range of the audio signal. In fact, in some classical recordings, it is easy to see the louder passages in the music because the grooves are intentionally spaced further apart, as is illustrated in Figure 3.9.

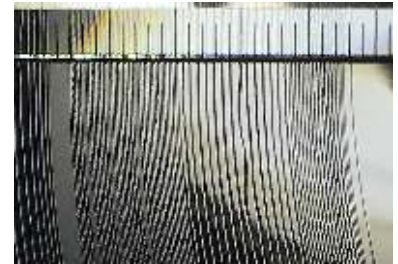

Figure 3.9: An extreme example of a disc in which the groove spacing has been varied to accommodate louder passages in the music. One consequence of this is that this side of the disc contains a single piece of music lasting only 15 minutes and 34 seconds. The ruler at the top of the photo is graduated in mm.

The Beogram 4000c is factory-calibrated so that a standard reference modulation velocity of 35.4 mm/sec on one channel at 1 kHz will produce an output of 354 mV RMS at the output. For a sine wave, this corresponds to a peak level of 500 mV. It can safely be connected to a Line input of any audio device.

However, it should be noted that the maximum possible output level of the turntable is 8.0 V peak, which may, in fact, be reached with some discs. Consequently, it should be noted that playing these recordings with higher modulation velocities (and therefore higher output levels) may result in the Beogram 4000c clipping the Line input stage of a device connected “downstream” (depending on its maximum allowed input level).

If you are connecting the Beogram 4000c to the RCA Line input of a Beolab 90 or Beolab 50, it is recommended that you set the Maximum Input Level

<sup>5</sup>(35.4\*2) / √2 because the two channels are modulated at an angle of 45° to the surface of the disc.

of that input on the loudspeaker to 4.0 V RMS (which corresponds to 5.7 V peak) or 6.5 V RMS (9.2 V peak) using its Input Setup menu. This will ensure that you maintain adequate headroom for playback.

A large part of the performance of a turntable is dependent on the physical contact between the surface of the vinyl and the tip of the stylus. In general terms, as we've already seen, there is a groove with two walls that vary in height, almost independently and the tip of the stylus traces that movement accordingly. However, it is necessary to get down to the microscopic level to consider this behaviour in more detail.

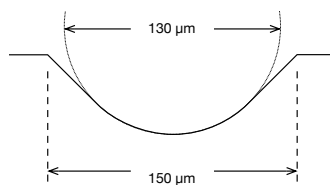

When a record is mastered (meaning, when the master disc is created on a lathe) the groove is cut by a heated stylus that has a specific shape, shown in Figure 3.10. The depth of the groove can range from a minimum of 25 μm to a maximum of 127 μm, which, in turn varies the width of the groove. <sup>6</sup>

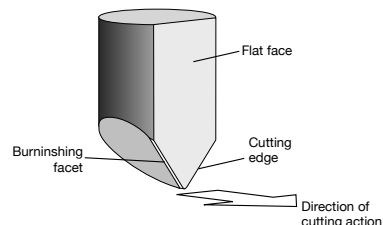

Figure 3.10: The cutting stylus used to create the groove in the master disc.



Figure 3.11: A Neumann-Teldec cutting head creating the groove in the master disc. The cutting stylus shown in Figure 3.10 can be seen just under the circular support under the head. (Wikimedia Commons)

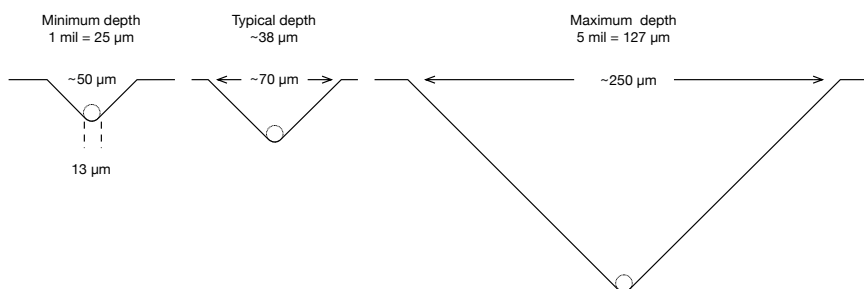

Figure 3.12: Dimensions of record grooves, drawn to scale. The figure on the left is typical for a 78 RPM shellac disc. The three grooves on the right show the possible variation in a 33 1/3 "microgroove" LP.

The result is a groove with a varying width and depth that are dependent on the decisions made by the mastering engineer, and a modulation displacement (the left/right size of the "wobble") that is dependent on the level of the audio signal that is being reproduced.

In a perfect situation, the stylus that is used to play that signal back on a turntable would have exactly the same shape as the cutting stylus, since this would mean that the groove is traced in exactly the same way that it was cut. This, however, is not practical for a number of reasons. As a result, there are a number of options when choosing the shape of the playback stylus.

### 3.3 Tip shape

The earliest styli were the needles that were used on 78 RPM gramophone players. These were typically made from steel wire that was tapered to a conical shape, and then the tip was rounded to a radius of about 150 μm, by tumbling them in an abrasive powder.<sup>7</sup> This rounded curve at the tip of the needle had a hemispherical form, and so styli with this shape are known as either *conical* or *spherical*.

The first styli made for "microgroove" LP's had the same basic shape as the steel predecessor, but were tipped with sapphire or diamond. The conical/spherical shape was a good

choice due to the relative ease of manufacture, and a typical size of that spherical tip was about 36 μm in diameter. However, as recording techniques and equipment improved, it was realised that there are possible disadvantages to this design.

Remember that the side-to-side shape of the groove is a physical representation of the audio signal: the higher the frequency, the smaller the wave on the disc. However, since the disc has a constant speed of rotation, the speed of the stylus relative to the groove is dependent on how far away it is from the centre of the disc. The closer the stylus gets to the centre, the smaller the circumference, so the slower the groove speed.

<sup>6</sup>"The High-fidelity Phonograph Transducer" B.B. Bauer, JAES 1977 Vol 25, Number 10/11, Oct/Nov 1977

<sup>7</sup>ibid.

If we look at a 12" LP, the smallest allowable diameter for the modulated groove is about 120 mm, which gives us a circumference of about 377 mm (or  $120 * \pi$ ). The disc is rotating 33 1/3 times every minute which means that it is making 0.56 of a rotation per second. This, in turn, means that the stylus has a groove speed of 209 mm per second. If the audio signal is a 20,000 Hz tone at the end of the recording, then there must be 20,000 waves carved into every 209 mm on the disc, which means that each wave in the groove is about 0.011 mm or 11  $\mu\text{m}$  long.

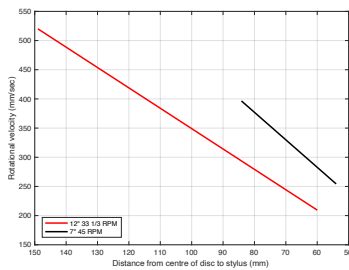

Figure 3.13: The relative speed of the stylus to the surface of the vinyl as it tracks from the outside to the inside radius of the record.

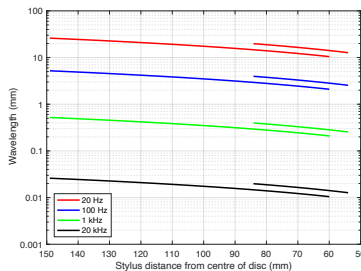

Figure 3.14: The wavelengths measured in the groove, as a function of the stylus's distance to the centre of a disc. The shorter lines are for 45 RPM 7" discs, the longer lines are for 33 1/3 RPM 12" LPs.

However, now we have a problem. If the "wiggles" in the groove have a total wavelength of 11  $\mu\text{m}$ , but the tip of the stylus has a diameter of about 36  $\mu\text{m}$ , then the stylus will not be able to track the groove because it's simply too big (just like the tires of your car do not sink to the bottom of every small

crack in the road surface). Figure 3.15 shows to-scale representations of a conical stylus with a diameter of 36  $\mu\text{m}$  in a 70  $\mu\text{m}$ -wide groove on the inside radius of a 33 1/3 RPM LP (60 mm from the centre of the disc), viewed from above. The red lines show the bottom of the groove and the black lines show the edge where the groove meets the surface of the disc. The blue lines show the point where the stylus meets the groove walls. The top plot is a 1 kHz sine wave and the bottom plot is a 20 kHz sine wave, both with a lateral modulation velocity of 70 mm/sec. Notice that the stylus is simply too big to accurately track the 20 kHz tone.

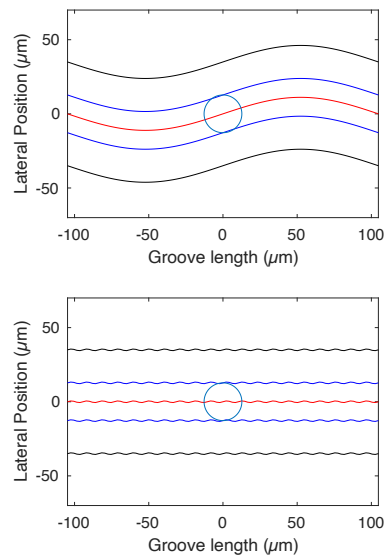

Figure 3.15: Scale representations of a conical stylus with a diameter of 36  $\mu\text{m}$  in a 70  $\mu\text{m}$ -wide groove on the inside radius of a 33 1/3 RPM LP, looking directly downwards into the groove. See the text for more information.

One simple solution was to "sharpen" the stylus; to make the diameter of the spherical tip smaller. However, this will result in at least three possible side effects. The first is that the tip will sink deeper into the groove, where dust and dirt particles accumulate, resulting in an increase in the noise floor, as was discussed above. The second is that when the tip is positioned deeper in the groove, it cannot be moved independently by the two walls of the groove as easily, therefore reducing the stereo separation of the output.

The third is that the point of contact between the stylus and the vinyl becomes smaller, which will result in more wear on the groove itself because the "footprint" of the tip is smaller. However, since the problem is in tracking the small wavelength of high-frequency signals, it is only necessary to reduce the diameter of the stylus in one dimension, thus making the stylus tip *elliptical* instead of conical. In this design, the tip of the stylus is wide, to sit across the groove, but narrow along the groove's length, making it small enough to accurately track high frequencies. An example showing a 0.2 mil x 0.7 mil (10 x 36  $\mu\text{m}$ ) stylus is shown in Figure 3.16. Notice that this shape can track the 20 kHz tone more easily, while sitting at the same height in the groove as the conical stylus in Figure 3.15.

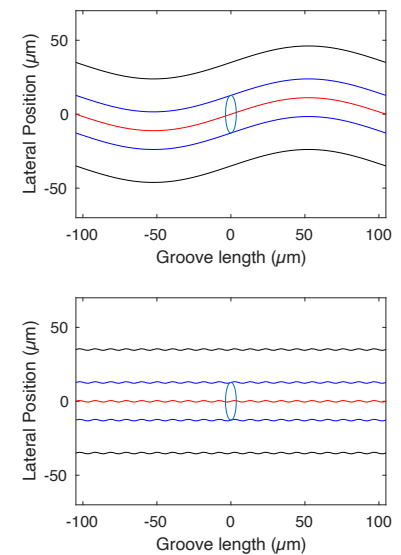

Figure 3.16: Scale representations of an elliptical stylus with diameters of 10 x 36  $\mu\text{m}$  in a 70  $\mu\text{m}$ -wide groove on the inside radius of a 33 1/3 RPM LP, looking directly downwards into the groove. See the text for more information.

Both the conical and the elliptical stylus designs have a common drawback in that the point of contact between the tip and the groove wall is extremely small. This can be seen in Figure 3.17, which shows various stylus shapes from the front. Notice the length of the contact between the red and black lines (the stylus and the

groove wall). As a result, both the groove of the record and the stylus tip will wear over time, generally resulting in an increasing loss of high frequency output. This was particularly a problem when the CD-4 Quadradisc format was introduced, since it relies on signals as

high as 45 kHz being played from the disc. In order to solve this problem, a new stylus shape was invented by Norio Shibata at JVC in 1973. The idea behind this new design is that the sides of the stylus are shaped to follow a much larger-radius circle than is

possible to fit into the groove, however, the tip has a small radius like a conical stylus. An example showing this general concept can be seen on the right side of Figure 3.17.

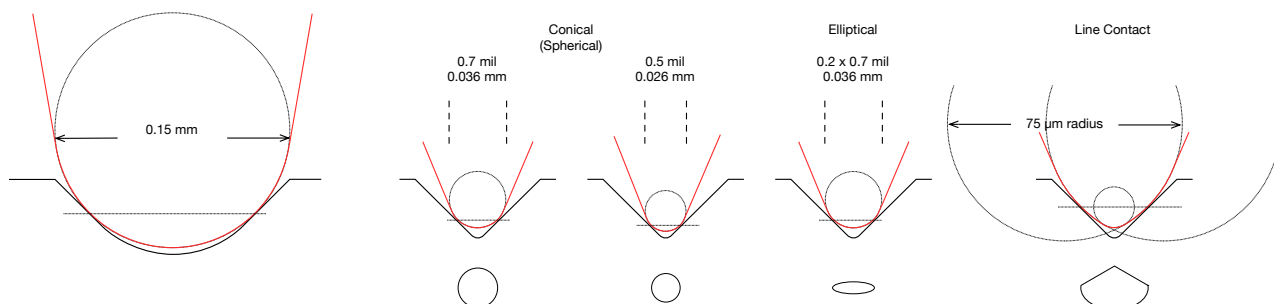

Figure 3.17: Dimensions of example styli, drawn to scale. The figure on the left is typical for a 78 RPM steel needle. The four examples on the right show different examples of tip shapes. These are explained in more details in the text. (For comparison, a typical diameter of a human hair is about 0.06 mm.)

There have been a number of different designs following Shibata's general concept, with names such as MicroRidge (which has an interesting, almost blade-like shape "across" the groove), Fritz-Geiger, Van-den-Hul, and Optimized Contour Contact Line. Generally, these designs have come to be known as *line contact* (or *contact line*) styli, because the area of contact between the stylus and the groove wall is a vertical line rather than a single point.

In 1973, Bang and Olufsen started working its own turntable that could play the new CD-4 Quadradisc format. This not only meant developing a new decoder with a 4-channel output, but also a stylus with a bandwidth reliably extending to approximately 45 kHz. This task was given to Villy Hansen, who was project manager for pickup development, despite being still relatively new to the company. Hansen proposed an improvement upon the Shibata grind (which was already commercially available by then) by making 4 facets instead of 2, resulting in a better shape for tracking the very high-frequency modulation. Although developed by Hansen, the new stylus became known as the "Pramanik

diamond", named after Subir K. Pramanik, who had started working as an engineer in Struer in 1971, but who had temporarily returned to India. The end result was a new pickup family that was initially launched with the top model, the MMC 6000.



Figure 3.18: An example of an elliptical stylus on the left vs. a line contact Pramanik grind on the right. Notice the difference in the area of contact between the styli and the groove walls.

### 3.4 Bonded vs. Nude

There is one small, but important point regarding a stylus's construction. Although the tip of the stylus is almost always made of diamond today, in lower-cost units, that diamond tip is mounted or *bonded* to a metal pin (typically steel, aluminium, or titanium) which is, in turn, connected to the cantilever (the long "arm" that connects back to the cartridge housing). This bonded design is

cheaper to manufacture, but it results in a high mass at the stylus tip, which means that it will not move easily at high frequencies.



Figure 3.19: Scale models (on two different scales) of different styli. The example on the left is bonded, the other four are nude.

In order to reduce mass, the metal pin is eliminated, and the entire stylus is made of diamond instead. This makes things more costly, but reduces the mass dramatically, so it is preferred if the goal is higher sound performance. This design is known as a *nude* stylus.



### 3.5 Tracking force

In order to keep the stylus tip in the groove of the record, it must have some force pushing down on it. This force must be enough to keep the stylus in the groove. However, if it is too large, then both the vinyl and the stylus will wear more quickly. Thus a balance must be found between “too much” and “not enough”.

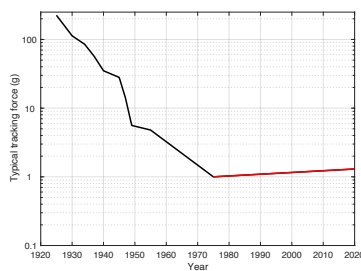

Figure 3.20: Typical tracking force over time. The red portion of the curve shows the recommendation for Beogram 4002 and Beogram 4000c.

As can be seen in Figure 3.20, the typical tracking force of phonograph players has changed considerably since the days of gramophones playing shellac discs, with values under 10 g being standard since the introduction of vinyl microgroove records in 1948. The original recommended tracking force of the Beogram 4002 was 1 g, however, this has been increased to 1.3 g for the Beogram 4000c in order to help track more recent recordings with higher modulation velocities and displacements.

### 3.6 Effective Tip Mass

The stylus’s job is to track all of the vibrations encoded in the groove. It stays in that groove as a result of the adjustable tracking force holding it down, so the moving parts should be as light as possible<sup>8</sup> in order to ensure that they can move quickly. The total *apparent* mass of the parts that are being moved as a result of the groove

modulation is called the *effective tip mass*. Intuitively, this can be thought of as giving an impression of the amount of inertia in the stylus.

It is important to not confuse the tracking force and the effective tip mass, since these are very different things. Imagine a heavy object like a 1500 kg car, for example, lifted off the ground using a crane, and then slowly lowered onto a scale until it reads 1 kg. The “weight” of the car resting on the scale is equivalent to 1 kg. However, if you try to push the car sideways, you will obviously find that it is more difficult to move than a 1 kg mass, since you are trying to overcome the inertia of all 1500 kg, not the 1 kg that the scale “sees”. In this analogy, the reading on the scale is equivalent to the Tracking Force, and the mass that you’re trying to move is the Effective Tip Mass. Of course, in the case of a phonograph stylus, the opposite relationship is desirable; you want a tracking force high enough to keep the stylus in the groove, and an effective tip mass as close to 0 as possible, so that it is easy for the groove to move it.

### 3.7 Compliance

Imagine an audio signal that is on the left channel only. In this case, the variation is only on one of the two groove walls, causing the stylus tip to ride up and down on those bumps. If the modulation velocity is high, and the effective tip mass is too large, then the stylus can lift off the wall of the groove just like a car leaving the surface of a road on the trailing side of a bump. In order to keep the car’s wheels on the road, springs are used to push them back down before the rest of the car starts to fall. The same is true for the stylus tip. It’s being pushed back down into the groove by the cantilever’s rubber support that provides the spring. The amount of “springiness” is called the *compliance* of the stylus suspension. (Compliance is the

opposite of spring stiffness: the more compliant a spring is, the easier it is to compress, and the less it pushes back.)

Like many other stylus parameters, the compliance is balanced with other aspects of the system. In this case it is balanced with the effective mass of the tonearm (which includes the components for controlling the tracking force), resulting in a resonant frequency. In a poorly-designed system, if that frequency is too high, then it can be audible as a low-frequency tone that is “singing along” with the music. If it’s too low, then in a worst-case situation, the stylus can jump out of the record groove.

If a turntable is very poorly adjusted, then (in an absolute worst-case) a high tracking force and a high stylus compliance (therefore, a “soft” spring) results in the entire assembly sinking down onto the record surface. A slight mis-adjustment can result in the electromagnetic system being unbalanced (for example, if the assembly is partly lowered, but not “bottoming out” on the vinyl surface), which will increase the distortion artefacts in the audio output. However, a high compliance is necessary for low-frequency reproduction, therefore the maximum tracking force is, in part, set by the compliance of the stylus.

If you are comparing the specifications of different cartridges, it may be of interest to note that compliance is often expressed in one of five different units, depending on the source of the information:

- “Compliance Unit” or “cu”
- mm/N  
millimetres of deflection per Newton of force
- $\mu\text{m/mN}$   
micrometres of deflection per thousandth of a Newton of force
- $\times 10^{-6}$  cm/dyn

<sup>8</sup>As will be discussed in the following section, it is also necessary that the compliance of the moving system is high enough as well.

hundredths of a micrometre of deflection per dyne of force

- $\times 10^{-6} \text{ cm}/10^{-5} \text{ N}$   
hundredths of a micrometre of deflection per hundred-thousandth of a Newton of force

Since

- $\text{mm}/\text{N} = 1000 \mu\text{m} / 1000 \text{ mN}$
- $1 \text{ dyne} = 0.00001 \text{ Newton}$

Then this means that all five of these expressions are identical, so, they can be interchanged freely. In other words:

$$\begin{aligned} &20 \text{ CU} \\ &= 20 \text{ mm} / \text{N} \\ &= 20 \mu\text{m} / \text{mN} \\ &= 20 \times 10^{-6} \text{ cm} / \text{dyn} \\ &= 20 \times 10^{-6} \text{ cm} / 10^{-5} \text{ N} \end{aligned}$$

### 3.8 Soundsmith SMMC20CL

Today, the Beogram 4000c is supplied with an SMMC20CL cartridge made by Soundsmith. This is a nude contact line diamond stylus with a solid sapphire cantilever. It is a variable reluctance design, based on the original Bang & Olufsen Micro Moving Cross construction.

The SMMC20CL has an effective tip mass of 0.32 mg, lower than the 0.5 mg of the original MMC 4000 cartridge, but slightly higher than the 0.22 mg in the MMC 6000 cartridge.

### 3.9 Tangential Tracking

When a record master is cut on a lathe, the cutter head follows a straight-line path as it moves from the outer rim to the inside of the disk. This means that it is always modulating in a direction that is perpendicular to the groove's relative direction of travel, regardless of its distance from the centre.

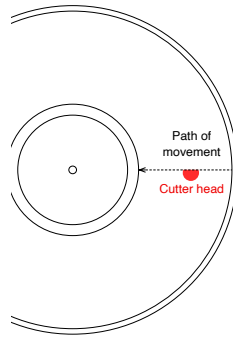

Figure 3.21: The direction of travel of the cutting head when the master disk is created on a lathe.

A turntable should be designed to ensure that the stylus tracks the groove made by the cutter head in all aspects. This means that this perpendicular angle should be maintained across the entire surface of the disk. However, in the case of a tonearm that pivots, this is not possible, since the stylus follows a circular path, resulting in an angular tracking error.

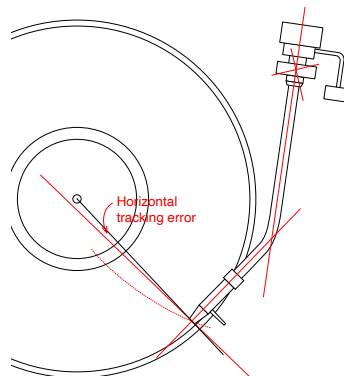

Figure 3.22: Any tonearm has some angular tracking error that varies with position on the disk.

The location of the pivot point, the tonearm's shape, and the mounting of the cartridge can all contribute to reducing this error. Typically, tonearms are designed so that the cartridge is angled to *not* be in-line with the pivot point. This is done to ensure that there can be two locations on the record's surface where the stylus is angled correctly relative to the groove.

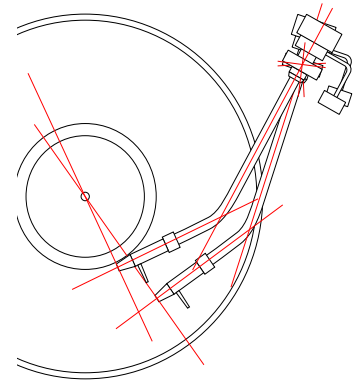

Figure 3.23: A correctly-designed and aligned pivoting tonearm has a tracking error of  $0^\circ$  at only two locations on the disk.

However, the only real solution is to move the tonearm in a straight line across the disc, maintaining a position that is tangential to the groove, and therefore keeping the stylus located so that its movement is perpendicular to the groove's relative direction of travel, just as it was with the cutter head on the lathe.

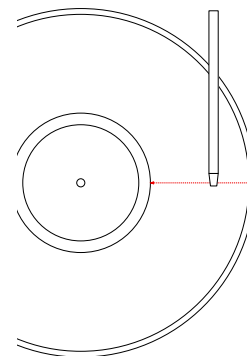

Figure 3.24: A tonearm that travels sideways, maintaining an angle that is tangent to the groove at the stylus.

In a perfect system, the movement of the tonearm would be completely synchronous with the sideways "movement" of the groove underneath it, however, this is almost impossible to achieve. In the Beogram 4000c, a detection system is built into the tonearm that responds to the angular deviation from the resting position. The result is that the tonearm "wiggles" across the disk: the groove pulls the stylus towards the centre of



the disk for a small distance before the detector reacts and moves the back of the tonearm to correct the angle.

Typically, the distance moved by the stylus before the detector engages the tracking motor is approximately 0.1 mm, which corresponds to a tracking error of approximately 0.044°.

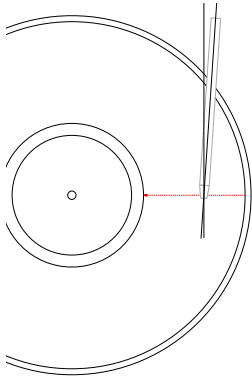

Figure 3.25: An exaggerated representation of the maximum tracking error of the tonearm before the detector engages and corrects.

One of the primary artefacts caused by an angular tracking error is distortion of the audio signal: mainly second-order harmonic distortion of sinusoidal tones, and intermodulation distortion on more complex signals.<sup>9</sup> It can be intuitively understood that the distortion is caused by the fact that the stylus is being moved at a different angle than that for which it was designed.

It is possible to calculate an approximate value for this distortion level using this equation:<sup>10</sup>

$$Hd \approx 100 * \frac{(\omega A \alpha)}{(\omega_r r)}$$

Where  $Hd$  is the harmonic distortion in percent,  $\omega$  is the angular frequency of the modulation caused by the audio signal (calculated using  $\omega = 2\pi F$ ),  $A$  is the peak amplitude in mm,  $\alpha$  is the horizontal tracking error (shown in Figure 3.22) in degrees,  $\omega_r$  is the angular frequency of rotation<sup>11</sup> and  $r$  is the radius (the distance of the groove from the centre of the disk).

This equation can be re-written, separating the audio signal and the rotation speed of the disk from the tonearm characteristics, as shown below.

$$Hd \approx 100 * \frac{(\omega A)}{(\omega_r)} * \frac{\alpha}{r}$$

This shows that, for a given audio frequency and disk rotation speed, the audio signal distortion is proportional to the horizontal tracking error over the distance of the stylus to the centre of the disk. This is the reason one philosophy in the alignment of a pivoting tonearm is to ensure that the tracking error is reduced when approaching the centre of the disk, since the smaller the radius, the greater the distortion.

It may be confusing as to why the position of the groove on the disk has an influence on this value. The reason is that the distortion is dependent on the wavelength of the signal encoded in the groove. The longer the wavelength, the lower the distortion. As was shown in Figure 3.13, the wavelength of a constant frequency is longer on the outer groove of the disk than on the inner groove.

Using the Beogram 4000c as an example at its worst-case tracking error of 0.044°: if we have a 1 kHz sine wave with a modulation velocity of 34.1 mm/sec on a 33 1/3 RPM LP on the inner-most groove then the resulting 2nd-harmonic distortion will be 0.7% or about -43 dB relative to the signal. At the outer-most groove (assuming all other variables remain constant), the value will be roughly half of that, at 0.3% or -50 dB.

<sup>9</sup>“Have Tone Arm Designers Forgotten Their High-School Geometry?” *The Audio Critic*, Vol. 1, No. 1, Jan./Feb., 1977.

<sup>10</sup>Tracking Angle in Phonograph Pickups; B.B. Bauer, *Electronics* (March 1945)

<sup>11</sup>This is the rotational speed of the record in radians per second. For example, at 33 1/3 RPM,  $\omega_r = 2 \pi 0.556 \text{ rev/sec} = 3.49$

## Audio Specifications

### 4.0.1 Magnitude Response

The magnitude response<sup>1</sup> of any audio device is a measure of how much its output level deviates from the expected level at different frequencies. In a turntable, this can be measured in different ways.

In the case of the Beogram 4000c, the magnitude response is measured from a standard test disc with a sine wave sweep ranging from at least 20 Hz to at least 20 kHz. The output level of this signal is recorded at the output of the device, and the level is analysed to determine how much it differs from the expected output. Consequently, the measurement includes all components in the audio path from the stylus tip, through the RIAA preamplifier, to the line-level outputs.

### 4.0.2 Rumble

In theory, an audio playback device only outputs the audio signal that is on the recording without any extra contributions. In practice, however, every audio device adds signals to the output for various reasons. As was discussed above, in the specific case of a turntable, the audio signal is initially generated by very small movements of the stylus in the record groove. Therefore, in order for it to work at all, the system must be sensitive to very small movements in general. This means that any additional movement can (and probably will) be converted to an audio signal that is added to the recording.

This unwanted extraneous movement, and therefore signal, is usually the result of very low-frequency vibrations that come from various sources. These can include things like mechanical vibrations of the entire turntable transmitted through the table from the

floor, vibrations in the system caused by the motor or imbalances in the moving parts, warped discs which cause a vertical movement of the stylus, and so on. These low-frequency signals are grouped together under the heading of *rumble*.

A rumble measurement is performed by playing a disc that has no signal on it, and measuring the output signal's level. However, that output signal is first filtered<sup>2</sup> to ensure that the level detection is not influenced by higher-frequency problems that may exist.

If the standard being used for the rumble measurement is the DIN 45 539 specification, then the resulting value is stated as the level difference between the measured filtered noise and the standard output level, equivalent to the output when playing a 1 kHz tone with a lateral modulation velocity of 70.7 mm/sec. In other words, it states how much quieter the rumble is than a relatively loud audio signal.

### 4.0.3 Rotational speed

Every recording / playback system, whether for audio or for video signals, is based on the fundamental principle that the recording and the playback happen at the same rate. For example, a film that was recorded at 24 frames (or photos) per second (FPS) must also be played at 24 FPS to avoid objects and persons moving too slowly or too quickly. It's also necessary that neither the recording nor the playback speed changes over time.

A phonographic LP is mastered with the intention that it will be played back at a rotational speed of 33 1/3 RPM (Revolutions Per Minute) or 45 RPM, depending on the disc. (These correspond to 1 revolution either every 1.8 seconds or every 1 1/3 seconds respectively.) We assume that the

rotational speed of the lathe that was used to cut the master was both very accurate and very stable. Although it is the job of the turntable to duplicate this accuracy and stability as closely as possible, measurable errors occur for a number of reasons, both mechanical and electrical. When these errors are measured using especially-created audio signals like pure sine tones, the results are filtered and analyzed to give an impression of how audible they are when listening to music. However, a problem arises in that a simple specification (such as a single number for "Wow and Flutter", for example) can only be correctly interpreted with the knowledge of how the value is produced.

## Accuracy

The first issue is the simple one of accuracy: is the turntable rotating the disc at the correct *average* speed? In the Beogram 4000c, this speed is governed by a tachometer built into the drive motor, that (like on almost all turntables) can be adjusted by the user using the controls shown in Figure 4.1. These adjustments allow for a usable range of  $\pm 3\%$ , which in music terms is equivalent to  $\pm$  half of a semitone.

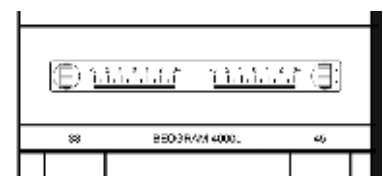

Figure 4.1: The fine adjustment controls for the 33 1/3 and 45 RPM settings.

## Stability

Like any audio system, regardless of whether it's analogue or digital, the playback speed of the turntable will vary over time. As it increases and decreases, the pitch of the music at the output will increase and decrease proportionally. This is unavoidable.

<sup>1</sup>This is the correct term for what is typically called the "frequency response". The difference is that a magnitude response only shows output level vs. frequency, whereas the frequency response would include both level and phase information.

<sup>2</sup>The characteristics of the filters are defined in internal standards such as DIN 45 539 and IEC98-1964.

Therefore, there are two questions that result:

- How much does the speed change?
- What is the rate and pattern of the change?

In a turntable, the amount of the change in the rotational speed is directly proportional to the frequency shift in the audio output. Therefore for example, if the rotational speed decreases by 1% (for example, from 33 1/3 RPM to exactly 33 RPM), the audio output will drop in frequency by 1% (so a 440 Hz tone will be played as a  $440 \cdot 0.99 = 435.6$  Hz tone). Whether this is audible is dependent on different factors including

- the rate of change to the new speed (a 1% change 4 times a second is much easier to hear than a 1% change lasting 1 hour)
- the listener's abilities (for example, a person with "absolute pitch" may be able to recognise the change)
- the audio signal (It is easier to detect a frequency shift of a single, long tone such as a note on a piano or pipe organ than it is of a short sound like a strike of claves or a sound with many enharmonic frequencies such as a snare drum.)

In an effort to simplify the specification of stability in analogue playback equipment such as turntables, four different classifications are used, each corresponding to different rates of change. These are drift, wow, flutter, and scrape, the two most popular of which are wow and flutter, and are typically grouped into one value to represent them.

### Drift

Frequency *drift* is the tendency of a playback device's speed to change over time very slowly. Any variation that happens slower than once every 2 seconds (in other words, with a *modulation frequency* of less than 0.5 Hz) is considered to be drift. This is typically caused by changes such as temperature (as the playback device heats up) or variations in the power supply (due to changes in the mains supply, which can vary with changing loads throughout the day).

### Wow

*Wow* is a modulation in the speed ranging from once every 2 seconds to 6 times a second (0.5 Hz to 6 Hz). Note that, for a turntable, the rotational speed of the disc is within this range. (At 33 1/3 RPM: 1 revolution every 1.8 seconds is equal to approximately 0.556 Hz.)

### Flutter

*Flutter* describes a modulation in the speed ranging from 6 to 100 times a second (6 Hz to 100 Hz).

### Scrape

*Scrape* or *scrape flutter* describes changes in the speed that are higher than 100 Hz. This is typically only a problem with analogue tape decks (caused by the magnetic tape sticking and slipping on components in its path) and is not often used when classifying turntable performance.

## Measurement and Weighting

The easiest accurate method to measure the stability of the turntable's speed within the range of Wow and Flutter is to follow one of the standard methods (of which there are many, but they are all similar<sup>3</sup>). A special measurement disc containing a sine tone, usually with a frequency of 3,150 Hz is played to a measurement device which then does a frequency analysis

of the signal. In a perfect system, the result would be a 3,150 Hz sine tone. In practice, however, the frequency of the tone varies over time, and it is this variation that is measured and analysed.

There is general agreement that we are particularly sensitive to a modulation in frequency of about 4 Hz (4 cycles per second) applied to many audio signals. As the modulation gets slower or faster, we are less sensitive to it, as was illustrated in the example above: (a 1% change 4 times a second is much easier to hear than a 1% change lasting 1 hour).

So, for example, if the analysis of the 3,150 Hz tone shows that it varies by  $\pm 1\%$  at a frequency of 4 Hz, then this will have a bigger impact on the result than if it varies by  $\pm 1\%$  at a frequency of 0.1 Hz or 40 Hz. The amount of impact the measurement at any given modulation frequency has on the total result is shown as a "weighting curve" in Figure 4.2.

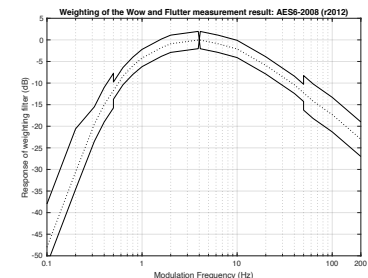

Figure 4.2: Weighting applied to the Wow and Flutter measurement in most standard methods. See the text for an explanation.

As can be seen in this curve, a modulation at 4 Hz has a much bigger weight (or impact) on the final result than a modulation at 0.315 Hz or at 140 Hz, where a 20 dB attenuation is applied to their contribution to the total result. Since attenuating a value by 20 dB is the same as dividing it by 10; a  $\pm 1\%$  modulation of the 3,150 Hz tone at 4 Hz will produce the same result as a  $\pm 10\%$  modulation of the

<sup>3</sup>Examples of these standards are AES6-2008, CCIR 409-3, DIN 45507, and IEC-386

3,150 Hz tone at 140 Hz, for example.

This shows just one example of why comparing one Wow and Flutter measurement value should be interpreted very cautiously...

## Expressing the result

When looking at a Wow and Flutter specification, one will see something like <0.1%, <0.05% (DIN), or <0.1% (AES6). Like any audio specification, if the details of the measurement type are not included, then the value is useless. For example, "W&F: <0.1%" means nothing, since there is no way to know which method was used to arrive at this value.<sup>4</sup>

If the standard is included in the specification (DIN or AES6, for example), then it is still difficult to compare wow and flutter values. This is because, even when performing identical measurements and applying the same weighting curve shown in Figure 4.2, there are different methods for arriving at the final value. The value that you see may be a peak value (the maximum deviation from the average speed), the peak-to-peak value (the difference between the minimum and the maximum speeds), the RMS (a version of the average deviation from the average speed), or something else.

The AES6-2008 standard, which is the currently accepted method of measuring and expressing the wow and flutter specification, uses a "2 $\sigma$ " or "2-Sigma" method, which is a way of looking at the peak deviation to give a kind of "worst-case" scenario. In this method, the 3,150 Hz tone is played from a disc and captured for as long a time as is possible or feasible. Firstly, the average value of the actual frequency of the output is found (in theory, it's fixed at 3,150 Hz, but this is never true). Next, the short-term variation of the actual frequency over time is compared to the average, and weighted using the filter shown in

Figure 4.2. The result shows the instantaneous frequency variations over the length of the captured signal, relative to the average frequency (however, the effect of very slow and very fast changes have been reduced by the filter). Finally, the standard deviation of the variation from the average is calculated, and multiplied by 2 (hence "2-Sigma", or "two times the standard deviation"), resulting in the value that is shown as the specification. The reason two standard deviations is chosen is that (in the typical case where the deviation has a Gaussian distribution) the actual Wow & Flutter value should exceed this value no more than 5% of the time.

The reason this method is preferred today is that it uses a single number to express not only the wow and flutter, but the probability of the device reaching that value. For example, if a device is stated to have a Wow and Flutter of "1% (AES6)", then the actual deviation from the average speed will be less than 1% for 95% of the time you are listening to music. The principal reason this method was not used in the 1970s when the Beogram 4002 turntable was released is that it requires statistical calculations applied to a signal that was captured from the output of the turntable, an option that was not available 45 years ago. The older DIN method that was used showed a long-term average level that was being measured in real-time using analogue equipment such as the device shown in Figure 4.3.



Figure 4.3: Bang & Olufsen WM1, analogue wow and flutter meter.

Unfortunately, however, it is still

impossible to know whether a specification that reads "Wow and Flutter: 1% (AES6)" means 1% deviation with a modulation frequency of 4 Hz or 10% deviation with a modulation frequency of 140 Hz - or something else. It is also impossible to compare this value to a measurement done with one of the older standards such as the DIN method, for example.

<sup>4</sup>Similarly, a specification like "Frequency Range: 20 Hz to 20 kHz" means nothing, since there is no information about the levels used to define the range.

## Reading the measurement datasheet

Each Beogram 4000c includes a datasheet detailing the results of the measurements of the turntable including the installed SoundSmith cartridge. These measurements were done to verify that the performance of each turntable was within the required specifications, however, they can also be used to help adjust parameters in the playback system to improve the overall experience.

Figure 5.1: The final verification sheet that is included with each Beogram 4000c.

The following are some explanations of how these measurements are performed, using some examples taken from actual products.

### 5.1 Measurements from Vinyl

In order to test the entire system, including the motor and motor control, the belt, bearings, pickup cartridge, RIAA preamplifier, and all other components in the signal path, various signals are played from different disks and the resulting outputs are analysed differently.

#### 5.1.1 Magnitude Response

The magnitude response of the total system is measured using a standard test disc that contains a track with a sinusoidal wave. The frequency of that tone is swept from a low frequency to a high frequency, typically using a logarithmic scaling. This means that it changes by the same number of octaves per second (instead of the same number of Hertz per second).

In the case of the measurements supplied with the Beogram 4000c, the test disk we use is the JCV TRS-1007, which contains a 20 Hz - 20,000 Hz logarithmic sweep that lasts 50 seconds (5 seconds per octave), first played on the left channel, then on the right channel.

One important thing to note is that the sinusoidal tone on the LP has a nominal level of 35.4 mm/sec modulation velocity. At 1 kHz, the level is 1 dB below this: at 31.7 mm/sec. Below 1 kHz, the signal has a level that follows the RIAA standard. However, above 4 kHz the signal on the disk has a constant velocity without the RIAA emphasis applied. This is because if a mastering lathe is pushed to cut a groove at high levels in the very high frequency bands, the power required will burn out the coils in the cutter head.

Consequently, if the sinusoidal sweep is played through a standard RIAA preamplifier, the result will be a magnitude response that appears to be flat below about 1 kHz, but follows the RIAA de-emphasis curve above 4 kHz.

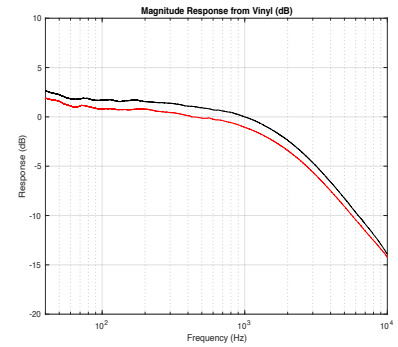

Figure 5.2: Raw results from the Magnitude Response measurement. This is processed to generate the result in Figures 5.3, for example.

The two tracks from the JVC disk are played and captured by a measurement system. The resulting recordings are analysed to find the level output over the 50 seconds of the sweep signal. An example of the “raw” resulting measured outputs from a total system are shown in Figure 5.2.

Since it’s difficult to interpret the actual magnitude response of the system from this recording, the expected response (flat below 1 kHz and following the RIAA response above 4 kHz) is subtracted from the measurements, resulting in the magnitude response plot shown in Figure 5.3.

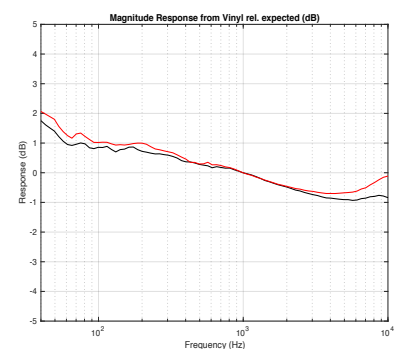

Figure 5.3: Results from a magnitude response measurement. The result of this measurement was  $\pm 1.4$  dB.

Note that these curves have been normalised to a nominal level of 0 dB at 1 kHz. This is because this measurement is only for the magnitude response of each channel. For each channel, the total

maximum-to-minimum deviation is found in the frequency range of 40 Hz to 10 kHz, and the worst-case of the two channels is listed in the “Magnitude Response” value in the data sheet.

### 5.1.2 Channel Matching

One thing that is easily noticeable in the curves in Figure 5.2 is that the two channels do not have the same output: the left channel (the black curve) is louder than the right channel. The difference in those two levels can be found by simply subtracting the levels in one from the other over the entire frequency range.

The result of the measurement shown in this example, written in the datasheet, was  $-0.7 \text{ dB} \pm 0.4 \text{ dB}$ . This means that, on average, the right channel is 0.7 dB quieter than the left channel (a positive value would indicate that the right channel is louder). However, the  $\pm 0.4 \text{ dB}$  means that the right channel ranges from being 1.1 dB to 0.3 dB quieter, depending on the frequency.

Consequently, if this Beogram 4000c were connected to a system that has individual level controls for the left and right audio channels, then it is recommended to increase the right channel by 0.5 to 1 dB higher than the left channel to offset this average difference.

For more discussion of this, please see the section below where the Channel Matching measurement of the built-in RIAA preamplifier is discussed.

### 5.1.3 Crosstalk

As mentioned above, the 50-second sweep signals are on a single channel per track. While that sweep is being played, the other audio channel should be silent. Therefore, in theory, the output of the turntable will have a

swept sinusoid on one channel, and nothing on the other. In practice however, this is impossible, since there is always some amount of crosstalk: “bleeding” of signal from one channel to the other. The question then is: how much crosstalk is there between the two output channels, when measured from the surface of the vinyl record?

This can be answered by measuring and comparing the output levels of the two audio channels while the sweep is played on only one of them, and plotting the result as a function of frequency, as is shown in Figure 5.4.

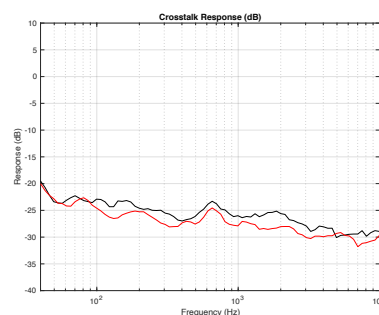

Figure 5.4: Results from a crosstalk measurement. The result of this measurement was  $-25.3 \text{ dB}$ .

Here, it can be seen that, within the frequency range of 40 Hz to 10 kHz, the crosstalk is always lower than 20 dB. This means that, at any frequency in that range, when a signal should be played on only one output channel at some level, the signal that “leaks” to the other channel is no more than 1/10 of that level (equivalent to  $-20 \text{ dB}$ ).

The specification written on the data sheet is the worst-case of the two audio channels, measured at 1 kHz, however, as can be seen in the figure, this is a good estimate for the entire frequency range.

### 5.1.4 Rumble

As was discussed in Section 4.0.2, all turntables output some low-frequency noises that are typically caused by

mechanical vibrations from the motor, bearing, the table, and the floor, resulting in relative movement of the vinyl surface and the pickup cartridge. This measurement is extremely dependent not only on the mechanical coupling of the various components in the system, but also on the resonances of those parts (including the table top, the turntable chassis, and the tonearm). This is very well-explained in a technical paper from Brüel and Kjær, available online.<sup>1</sup>

The measurement of the Beogram 4000c was performed on a large, solid table on a concrete basement floor to ensure that no extraneous vibrations were influencing the measurement. Two recordings are made for this: the first is a capture of a track from the B&K QR 2010 test disk which contains a 1 kHz tone with a modulation velocity of 70.1 mm/sec/channel (or 100 mm/sec lateral velocity). This is used as the reference level. The second track contains silence.<sup>2</sup>

Both tracks are captured from the output of the turntable’s RIAA preamplifier, the silent track is filtered using the equalisation specified in DIN 45 539, and the RMS levels of the two signals are compared. The difference in those two levels is listed in the datasheet for the turntable.

### 5.1.5 Wow and Flutter

Each turntable’s wow and flutter behaviour is measured using a standard 3.15 kHz sinusoidal tone, played from the B&K QR 2010 for 40 seconds. This is captured, and the actual frequency of the signal is compared to the expected 3,150 Hz for the full duration of the recording. This deviation over time is processed using the filter shown in Figure 4.2 and the result is plotted, as shown in Figure 5.5.

<sup>1</sup> Audible Effects of Mechanical Resonances in Turntables; Brüel and Kjær Application Note (1977)

<sup>2</sup> Note that this is not merely the lead-out groove at the end of a disk, since this would include a click every 1.8 seconds where the groove meets the final circle.



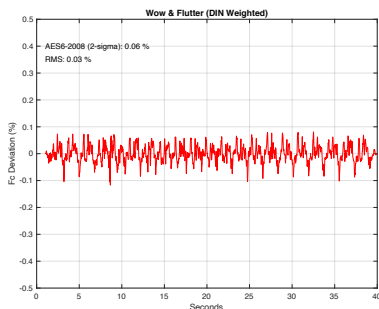

Figure 5.5: Detailed results from a wow and flutter measurement.

This shows the *instantaneous* variations in playback speed of the entire system over time. During the early development of the Beogram 4000c restoration project, this data was used to diagnose the various sources of wow and flutter, primarily by doing a frequency analysis of this change in frequency. For example, a deviation in frequency with a repetition rate of 0.556 Hz can be attributed to a problem in the bearing or the platter; a repetition at a higher frequency might point to an issue in the motor; whereas a lower-frequency periodic variation may be caused by irregularities in the belt compliance.

Although the wow and flutter measurement is based on the detection of instantaneous changes in the rotation speed over time, there are various methods of interpreting and stating the result. We have chosen to use the AES6-2008 Standard, as has already been explained in Section 4.0.3.4.

### 5.1.6 Frequency Drift

The data shown in Figure 5.5 can also be used to calculate the long-term frequency drift of the system. This is done by making a longer-term running average of the actual frequency of the signal when playing the 3.15 kHz tone, and measuring the worst-case deviation over time.

## 5.2 RIAA Preamp

All of the specifications listed above show the behaviour of the entire playback system from the surface of the vinyl to the analogue electrical output of the turntable. However, it is also useful to know the behaviour of the signal path's electrical components in isolation, without the pickup cartridge. The main reason for this is the fact that the pickup cartridge will require replacement over time, since the stylus does wear with use. Typical recommendations are that a diamond stylus should be replaced after 500 to 1000 hours of playing time.

Consequently, it is useful to know the behaviour of the turntable without the supplied pickup, since this will be the common element in the system over time.

This portion of the system is measured by sending a signal from a measurement system (simulating the output of the pickup cartridge) into the input of the preamplifier and capturing the resulting output of the system.

### 5.2.1 Magnitude Response Deviation

The expected magnitude response of a standard RIAA preamplifier is shown in Figure 2.5. The measurement system measures the actual response of the RIAA preamplifier on-board the Beogram 4000c and subtracts the expected response to produce a plot like the one in Figure 5.6. This shows the amount by which the magnitude response of the Beogram 4000c's RIAA preamplifier deviates from the expected response.

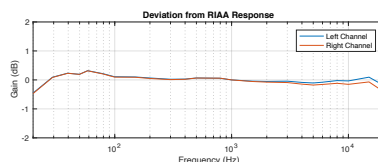

Figure 5.6: Results from a RIAA magnitude response measurement. The result of this measurement is a value of  $\pm 0.4$  dB

There are two things to notice in this plot. The first is that there is some measurable deviation from the expected response. The second is the fact that the two channels are not identical. Both of these issues are due to the small variations in the values of the components (resistors and capacitors, for example), despite the fact that a 1% tolerance specification is used.

The value written in the datasheet is the maximum deviation from the expected response, taking the worst of the two channels if they are different.

### 5.2.2 Channel Matching

As mentioned above, the left and right channels of the RIAA preamplifier do not have absolutely identical responses. The "Channel Matching" specification tells the maximum amount of difference within the frequency range of 20 Hz to 20 kHz. This is simply done by subtracting one of the curves in Figure 5.6 from the other and analysing the result, shown in Figure 5.7.

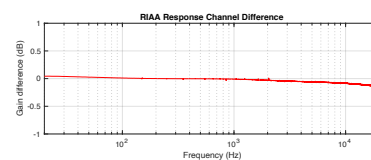

Figure 5.7: Results from a RIAA channel-matching measurement. The result of this measurement is a value of  $\pm 0.1$  dB

As can be seen by comparing Figure 5.7 to the example of the Channel Matching value for the entire system ( $-0.7$  dB  $\pm 0.4$  dB), the primary contributor of this difference is the pickup cartridge (this is quite normal). Although the two gain values of the RIAA preamplifier can be adjusted to correct for this difference in the pickup, this would not be the correct solution, since a new cartridge will have a different difference, with the possible result being that the RIAA gain compensation actually making the problem worse in the second cartridge. This is why it is recommended that, in



cases where you wish to correct for the gain offset, this should be done as a “temporary” measure in the playback system.

Attentive readers may notice some small spikes in the plot in Figure 5.7. These are merely artefacts of the measurement system, revealed by the

subtraction of the two curves. They are not reflective of actual differences in the preamplifier’s responses.

## Beogram 4000c Specifications

<b>Turntable</b>	<b>Maximum</b>	<b>Typical</b>
RIAA Gain, 1 kHz		41.8 dB ± 0.2 dB
Maximum Output	> 8.0 V Peak	
Deviation from RIAA standard, 20 - 20,000 Hz	< ± 1.0 dB	± 0.5 dB
Channel difference, 20 - 20,000 Hz	< ± 1.0 dB	± 0.2 dB
Rumble (DIN 45 539)*	> 50 dB	60 dB
Wow and flutter (AES6-2008)	< 0.12 %	0.07%
Speed drift (IEC-386)	< 0.15 %	0.07 %
Horizontal tracking error	< 0.04°	
<b>Pickup Cartridge</b>		Soundsmith SMMC20CL
Stylus		Nude, 0.12 mm square
Radius of curvature		Contact Line
Recommended tracking force		1.3 g
Compliance		28 μm/mN
Effective tip mass		0.32 mg
<b>General information</b>		
Automatic speed selection		Yes
Speeds		33 1/3 and 45 RPM
Speed control range		± 3%
Dial for speed		2 pointers
Tonearm		Tangential
Lift system		Electronic
Automatic pickup movement		Yes
Automatic record size		Yes
Motor		Controlled synchronous
Drive system		Belt
Dustcover		Hinged and detachable
Power supply: Input Voltage**		110/130, 220/240 V RMS
Power supply: Frequency		50, 60 Hz
Dimensions W x H x D		49 x 10 x 38 cm
Weight		12 kg

\* Measurement includes Soundsmith SMMC20CL

\*\* Power supply does not switch automatically

## Further Reading

Audible Effects of Mechanical Resonances in Turntables; Brüel and Kjær Application Note (1977)

Audio Measurement Handbook; Bob Metzler, Audio Precision Inc. (1993)

Basic Disc Mastering; Larry Boden (1981)

Cartridge / Arm / Turntable Followup: Loose Ends and New Developments, *The Audio Critic*, 1:43 (Spring/Fall, 1978)

Handbook for Sound Engineers: The New Audio Encyclopedia; ed. Glen Ballou (1987)

Have Tone Arm Designers Forgotten Their High-School Geometry?; *The Audio Critic*, 1:31 (Jan./Feb. 1977).

How the Stereo Disc Works; *Radio-Electronics*, (July 1958)

Manual of Analogue Sound Restoration Techniques; Peter Copeland (2008)

On the Mechanics of Tonearms; Dick Pierce (2005)

Pickup Arm Design; J.K. Stevenson, *Wireless World* (May/June, 1966)

Reproduction of Sound in High-Fidelity and Stereo Phonographs; Edgar Villchur (1966)

Tracking Angle in Phonograph Pickups; B.B. Bauer, *Electronics* (March 1945)

Journal of the Audio Engineering Society ([www.aes.org](http://www.aes.org))

- Centennial Issue: The Phonograph and Sound Recording After One-Hundred Years; Vol. 25, No. 10/11 (Oct./Nov. 1977)
- Factors Affecting the Stylus / Groove Relationship in Phonograph Playback Systems; C.R. Bastiaans; Vol. 15 Issue 4 (Oct. 1967)
- Further Thoughts on Geometric Conditions in the Cutting and Playing of Stereo Disk; C.R. Bastiaans; Vol. 11 Issue 1 (Jan. 1963)
- Record Changers, Turntables, and Tone Arms-A Brief Technical History, James H. Kogen; Vol. 25 (Oct./Nov. 1977)
- Some Thoughts on Geometric Conditions in the Cutting and Playing of Stereodisks and Their Influence on the Final Sound Picture; Ooms, Johan L., Bastiaans, C. R.; Vol. 7 Issue 3 (Jul. 1959)
- The High-Fidelity Phonograph Transducer, B.B. Bauer; Vol. 25 Issue 10/11 (Nov. 1977)

### DIN Standards

- 45 500: Hi-Fi Technics: Requirements for Disk Recording Reproducing Equipment
- 45 507: Measuring Apparatus for Frequency Variations in Sound Recording Equipment
- 45 538: Definitions for Disk Record Reproducing Equipment
- 45 539: Disk Record Reproducing Equipment: Directives for Measurements, Markings, and Audio Frequency, Connections, Dimensions of Interchangeable Pickups, Requirements of Playback Amplifiers
- 45 541: Frequency Test Record St 33 and M 33 (33 1/3 rev/min; Stereo and Mono)
- 45 542: Distortion Test Record St 33 and St 45 (33 1/3 or 45 rev/min; Stereo)
- 45 543: Frequency Response and Crosstalk Test Record
- 45 544: Rumble Measurement Test Record St 33 and M 33 (33 1/3 rev/min; Stereo and Mono)
- 45 545: Wow and Flutter Test Records, 33 1/3 and 45 rev/min
- 45 546: Stereophonic Disk Record St 45 (45 rpm)
- 45 547: Stereophonic Disk Record St 33 (33 1/3 rpm)
- 45 548 Aptitude for Performance of Disk Record Reproducing Equipment
- 45 549: Tracking Ability Test Record

IEC Publications

- 98: Recommendations for Lateral-Cut Commercial and Transcription Disk Recordings
- 98: Processed Disk Records and Reproducing Equipment
- 386: Method of Measurement of Speed Fluctuations in Sound Recording and Reproducing Equipment